

THE INFORMATION CONTAINED IN THIS DRAWING IS THE SOLE PROPERTY OF ABBOTT WORKHOLDING PRODUCTS. ANY REPRODUCTION IN PART OR WHOLE WITHOUT THE WRITTEN PERMISSION OF ABBOTT WORKHOLDING PRODUCTS IS PROHIBITED.

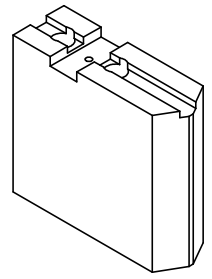

Tap Drill $\phi .159 \nabla 3/4''$
 10-32 UNC-2B $\nabla 1/2''$
 For Steel Key

$\phi 17/32''$ Thru
 $\phi 25/32''$ C'Bore
 2X

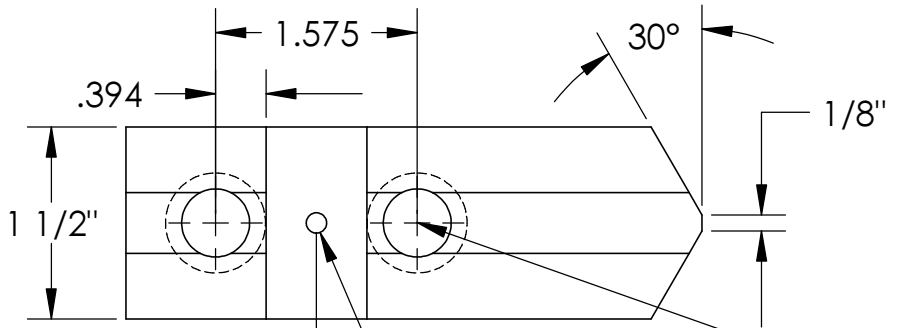
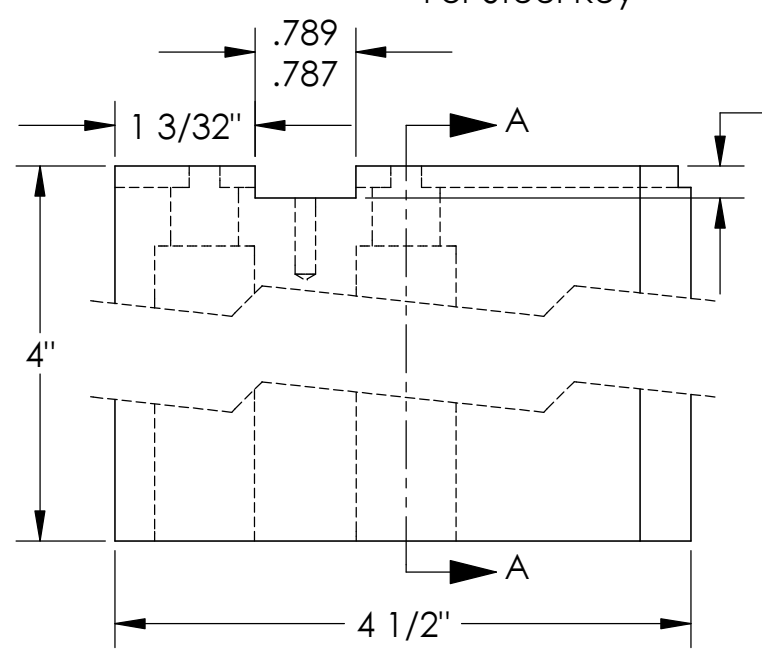

.250±.010
 Cross Slot Depth

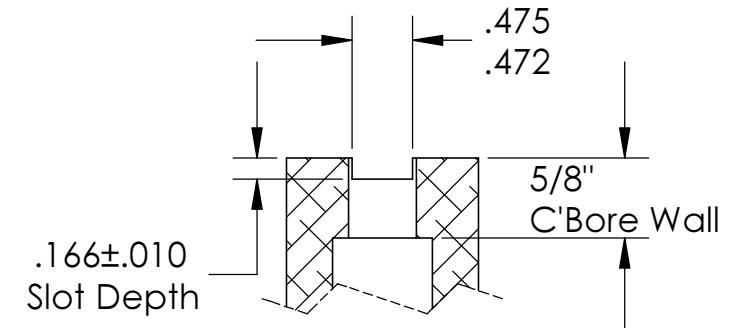

.166±.010
 Slot Depth

5/8"
 C'Bore Wall

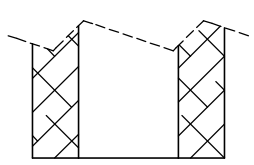

UNLESS OTHERWISE SPECIFIED
 DIMENSIONS ARE IN INCHES
 TOLERANCES ARE:
 FRACTIONS DECIMALS ANGLES
 $\pm 1/32$.XX±.015 $\pm 5^\circ$
 .XXX±.005
 .XXXX±.0005

DRAWN EWP	DATE 10/19/15
MATERIAL 6061	WEIGHT(POUNDS) 2.2
STYLE A	DISPOSITION Released

Abbott Workholding Products
 430 McCall Road
 Manhattan, KS 66502
 785-776-8555
 785-587-0004 Fax
 800-528-6459
 www.abbottworkholding.com
 engineering@abbottworkholding.com

CUSTOMER: Stock	SIZE A	Part Name MTG10MDA2	REV. --
--------------------	-----------	------------------------	------------