

THE INFORMATION CONTAINED IN THIS DRAWING IS THE SOLE PROPERTY OF ABBOTT WORKHOLDING PRODUCTS. ANY REPRODUCTION IN PART OR WHOLE WITHOUT THE WRITTEN PERMISSION OF ABBOTT WORKHOLDING PRODUCTS IS PROHIBITED.

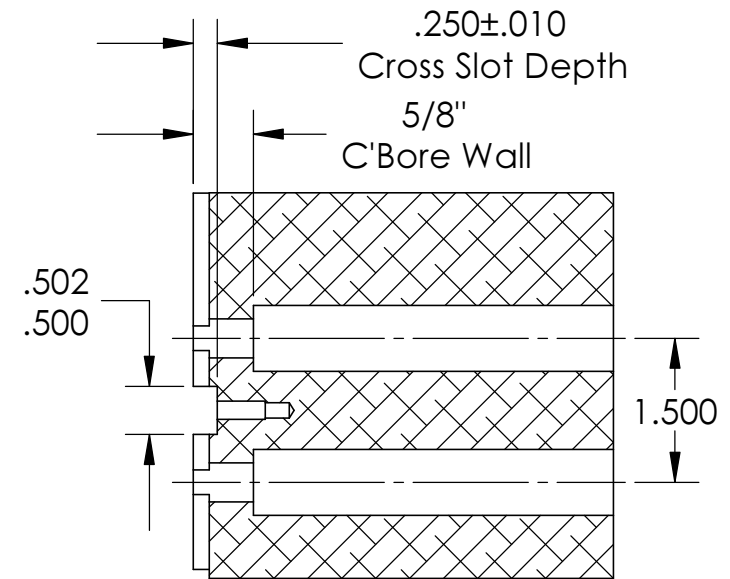
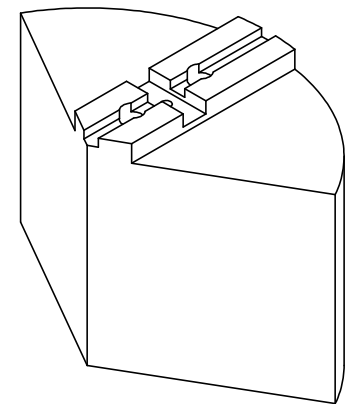
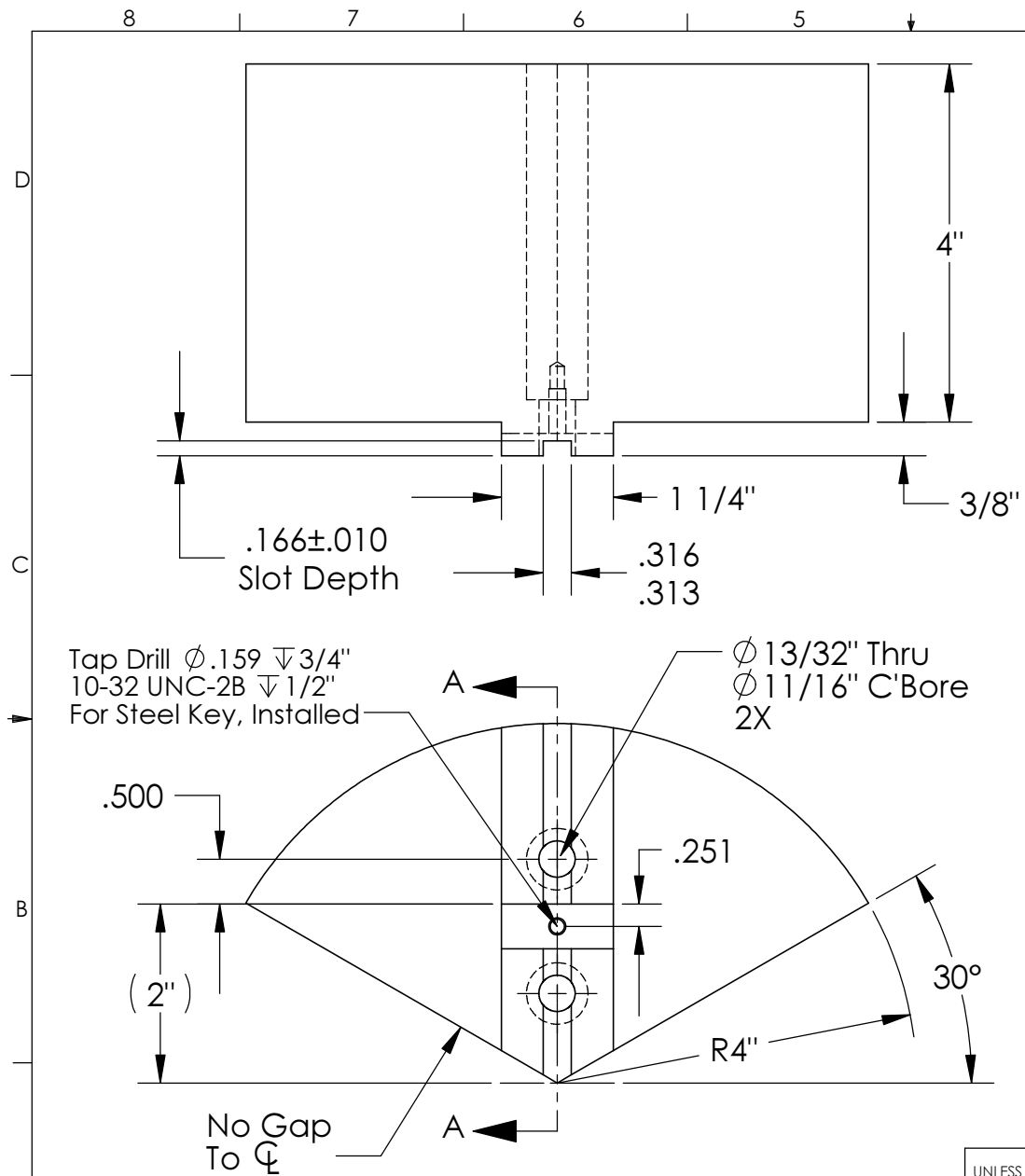

SECTION A-A

Tap Drill $\phi .159 \nabla 3/4"$
 10-32 UNC-2B $\nabla 1/2"$
 For Steel Key, Installed

$\phi 13/32"$ Thru
 $\phi 11/16"$ C'Bore
 2X

$.250 \pm .010$
 Cross Slot Depth
 5/8"
 C'Bore Wall

UNLESS OTHERWISE SPECIFIED
 DIMENSIONS ARE IN INCHES
 TOLERANCES ARE:
 FRACTIONS DECIMALS ANGLES
 $\pm 1/32$.XX $\pm .015$ $\pm 5^\circ$
 .XXX $\pm .005$
 .XXXX $\pm .0005$

DRAWN ZGG	DATE 05/03/16
MATERIAL 6061	WEIGHT(POUNDS) 6.5
STYLE D	DISPOSITION Released

Abbott Workholding Products

430 McCall Road
 Manhattan, KS 66502
 785-776-8555
 785-587-0004 Fax
 800-528-6459

www.abbottworkholding.com
 engineering@abbottworkholding.com

CUSTOMER: Stock	SIZE Part Name A TG86MDP1	REV. A
--------------------	------------------------------	-----------